



RE-POWERING GUIDELINES

If replacing a Briggs & Stratton engine with another Briggs & Stratton engine, use the original engine's model and type numbers to assure the correct replacement. If replacing a competitor's engine with a Briggs & Stratton engine, let the power level and features of the original engine, plus the expected work cycle, guide you in selecting the correct replacement. Also consider these factors:

1. Engine Selection

Match the engine's performance and cost to your specific application to get the optimum performance at an affordable price. That means better value for you.

- **Vanguard™ OHV** (overhead valve) engines are maximum performance, cast iron sleeved engines.
 - select for continuous heavy duty applications.
- **INTEK™ PRO, Industrial Plus™ and I/C®** (Industrial/Commercial) engines are cast iron sleeved.
 - select for medium duty commercial, industrial and rental use.
- **INTEK™ and PowerBuilt™** engines are aluminum cylinder bore OHV engines.
 - select for general consumer use.
- **Standard** engines are aluminum cylinder bore, side valve engines.
 - select for general consumer use.

2. Safety Points

For many safe hours of operation, it is important to maintain the original engine's power, starter type and position, fuel tank location, fuel line routing, muffler location, exhaust direction and muffler accessories (i.e., deflector, spark arrester, etc.). Reinstall all guards, shields and safety devices. Replace missing, worn or damaged parts.

3. Horizontal Crankshaft Engines

- Compare the overall engine size to avoid possible mounting interference
- Match the crankshaft
 - Diameter "A"
 - Height "B" (distance from base to crankshaft center line)
 - Length "C" (distance from oil seal/cover's mounting face to end of crankshaft)
- Match the crankshaft type, i.e., keyway, tapered or threaded
- Match the crankcase cover's tapped holes for mounting accessories (if applicable)
- Match the base mounting dimensions and bolt hole spacing

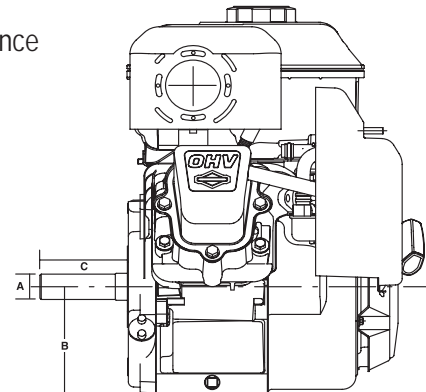

4. Vertical Crankshaft Engines

- Compare the overall engine size to avoid possible mounting interference
- Match the starter type and starter grip position "A"
- Match the crankshaft
 - Diameter "B"
 - Keyway type "C"
 - Length "D" (distance from mounting face of sump - not oil seal - to end of crankshaft)
- Match the mounting base dimensions and bolt hole spacing

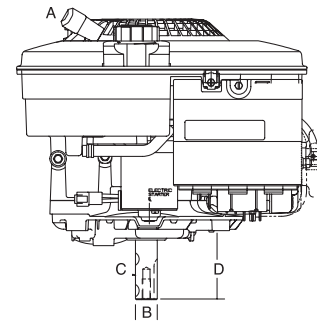

WARNING

Briggs & Stratton does not approve or authorize the use of these engines on 3-wheel All Terrain Vehicles (ATVs), motor bikes, fun/recreational go-karts, aircraft products or vehicles intended for use in competitive events. Use of these engines in such applications could result in property damage, serious injury (including paralysis), or even death.

SPECIFICATIONS OF SERVICE ENGINES

LEGEND OF ABBREVIATIONS

STARTER POSITION:	Number shown is “o’clock” position of rewind starter. Spark plug is considered to be the 12 o’clock position.
OIL FILLER & DRAIN:	“CS” – carburetor side, “OC” – opposite carburetor, “D” – dual (both sides), “T” (Three sided).
GOVERNOR:	“AV” – air vane, “M” – mechanical, “E” – electronic.
CONTROLS:	“MF” – manual friction, “R” – remote, “AG” – adjustable for a constant speed operation, “FC” – fixed speed control.
GROUND WIRE TERMINAL:	May be used with stop switch in remote location.
ACCESSORY MTG. BOSS or FLANGE MOUNTING:	Tapped holes in crankcase cover used to fasten clutch brackets, belt guards, etc.
DIMENSION:	Distance from end of crankshaft to one of the points listed below: (a) Oil seal on plain bearing horizontal crankshaft engines. (b) Mounting face of sump on vertical crankshaft engines. (c) Flange mounting face on horizontal crankshaft engines.
SHIPPING WEIGHT:	Gross Domestic Shipping Weight.

Briggs & Stratton Corporation believes the specifications in this brochure to be correct at time of printing. However, specifications, standard equipment, options, and colors are subject to change without notice.

ALL POWER RATINGS SHOWN IN THIS CATALOG ARE SUBJECT TO THE FOLLOWING:

The gross power rating labels for individual gas engine models is labeled in accordance with SAE (Society of Automotive Engineers) code J1940 (Small Engine Power & Torque Rating Procedure), and rating performance has been obtained and corrected in accordance with SAE J1995 (Revision 2002-05). Torque values are derived at 3060 RPM; horsepower values are derived at 3600 RPM. Actual gross engine power will be lower and is affected by, among other things, ambient operating conditions and engine-to-engine variability. Given both the wide array of products on which engines are placed and the variety of environmental issues applicable to operating the equipment, the gas engine will not develop the rated gross power when used in a given piece of power equipment (actual “on-site” or net power). This difference is due to a variety of factors including, but not limited to, accessories (air cleaner, exhaust, charging, cooling, carburetor, fuel pump, etc.), application limitations, ambient operating conditions (temperature, humidity, altitude), and engine-to-engine variability. Due to manufacturing and capacity limitations, Briggs & Stratton may substitute an engine of higher rated power for this Series engine.

Model-Type	588447-0305	58A447-0305
Number of cylinders	3 in-line	3 in-line
Bore x stroke [mm (in)]	72 x 78 (2.83 x 3.07)	72 x 78 (2.83 x 3.07)
Displacement [cc (cu in)]	952 (58.10)	952 (58.10)
Horsepower	31.0	34.0
Dry weight [kg (lb)]	84 (185)	84 (185)
Direction of rotation	Counterclockwise (looking at flywheel)	
Lubricating system	Pressure feed with spin-on oil filter	
Engine oil capacity [ltr (qtr)]	3.0 (3.2)	3.0 (3.2)
Cooling system	Liquid-cooled including water pump and fan (radiator optional)	
Alternator	12-40 Volt, 40 Amp	
Starter	12 Volt, 1.2 kw	
Shipping Weight [kg (lb)]	89 (196)	89 (196)

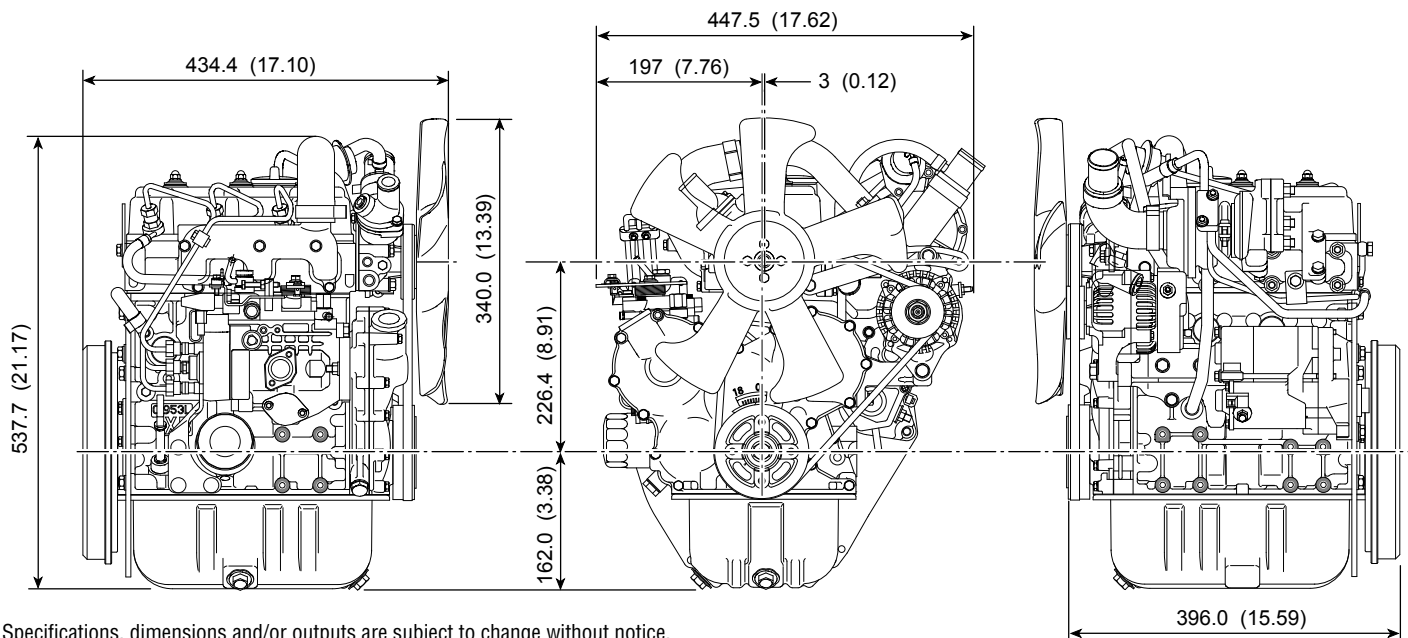
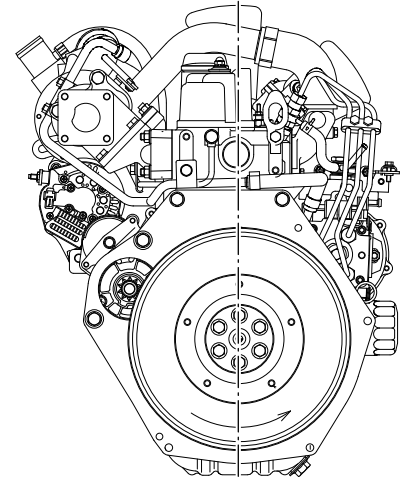
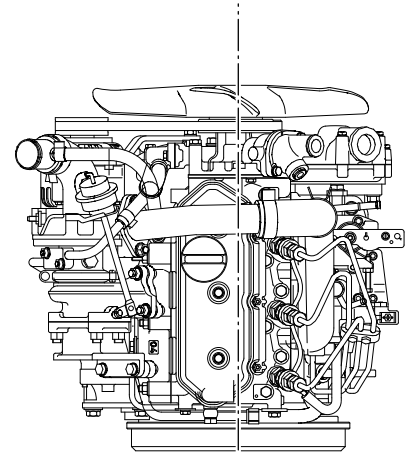

Specifications, dimensions and/or outputs are subject to change without notice.
All shipping weights are approximate.

YOUR KEY TO THE WORLD'S FINEST ENGINES

This chart explains the unique Briggs & Stratton numerical model designation system. It is possible to determine most of the important mechanical features of the engine by merely knowing the model number. Here is how it works:

- A. The first one or two digits indicate the approximate CUBIC INCH DISPLACEMENT.
- B. The first digit after the displacement indicates the BASIC DESIGN SERIES, relating to cylinder construction, ignition, general configuration, etc.
- C. The second digit after the displacement indicates ORIENTATION OF CRANKSHAFT.
- D. The third digit after the displacement indicates TYPE OF BEARINGS, and whether or not the engine is equipped with REDUCTION GEAR or AUXILIARY DRIVE.
- E. The last digit indicates the TYPE OF STARTER.

BRIGGS & STRATTON MODEL NUMBERING SYSTEM

A	FIRST DIGIT AFTER DISPLACEMENT <u>B</u>	SECOND DIGIT AFTER DISPLACEMENT <u>C</u>	THIRD DIGIT AFTER DISPLACEMENT <u>D</u>	FOURTH DIGIT AFTER DISPLACEMENT <u>E</u>
CUBIC INCH DISPLACEMENT	BASIC DESIGN SERIES	CRANKSHAFT ORIENTATION	PTO BEARING, REDUCTION GEAR, AUXILIARY DRIVE, LUBRICATION	TYPE OF STARTER
2	0	0 to 4 - Horizontal Shaft	0 - Plain Bearing/DU Non-Flange Mount	0 - Without Starter
5	1	5 to 9 - Vertical Shaft	1 - Plain Bearing Flange Mounting	1 - Rope Starter
6	2	A to G - Horizontal Shaft	2 - Sleeve Bearing Flange Mounting Splash Lube	2 - Rewind Starter
8	3	H to Z - Vertical Shaft	3 - Ball Bearing Flange Mounting Splash Lube	3 - Electric Starter Only 110 or 230 Volt Gear Drive
9	4		4 - Ball Bearing Flange Mounting Pressure Lubrication	4 - Electric Starter/110 or 230 Volt Gear Drive with Alternator
10	5		5 - Plain Bearing Gear Reduction (6 to 1) CCW Rotation Flange Mounting	5 - Electric Starter Only 12 or 24 Volt Gear Drive
11	6		6 - Ball Bearing Gear Reduction (2 to 1) CCW Rotation	6 - Alternator Only
12	7		7 - Plain Bearing Pressure Lubrication	7 - Electric Starter 12 or 24 Volt Gear Drive with Alternator
13	8		8 - Plain Bearing Auxiliary Drive (PTO) Perpendicular to Crankshaft	8 - Vertical Pull Starter or Side Pull Starter
15	9		9 - Plain Bearing Auxiliary Drive Parallel to Crankshaft	9 - Mechanical Starter
16	A to Z		A - Plain Bearing Pressure Lubrication Without Oil Filter	A - Electric Starter 12 or 24 Volt Gear Drive with Alternator and Inverter
18				
19				
20				
21				
22				
23				
24				
25				
28				
29				
30				
31				
32				
35				
38				
40				
42				
43				
44				
46				
47				
49				
52				
54				
58				
61				

EXAMPLE - To identify Model 303447:

<u>30</u>	<u>3</u>	<u>4</u>	<u>4</u>	<u>7</u>
30 Cubic Inch	Design Series 3	Horizontal Shaft	Ball Bearing Flange Mounting Pressure Lubrication	Electric Starter 12 or 24 Volt Gear Drive with Alternator

TYPE 1234-01, The type number identifies the engines mechanical parts, color of paint, decals, governed speed, and Original Equipment Manufacturer.

CODE 01061201, The code is the manufacturing date and is read as follows:

<u>YEAR</u>	<u>MONTH</u>	<u>DAY</u>	<u>ASSEMBLY LINE AND MANUFACTURING PLANT</u>
01	06	12	01

LIMITED WARRANTY

Briggs & Stratton Corporation will repair or replace, free of charge, any part(s) of the engine that is defective in material or workmanship or both. Transportation charges on product submitted for repair or replacement under this warranty must be borne by purchaser. This warranty is effective for and is subject to the time periods and conditions stated below. For warranty service, find the nearest Authorized Service Dealer in our dealer locator map at BRIGGSandSTRATTON.COM, or by calling 1-800-233-3723, or as listed in the 'Yellow Pages'.

There is no other expressed warranty. Implied warranties, including those of merchantability and fitness for a particular purpose, are limited to one year from purchase, or to the extent permitted by law. All other implied warranties are excluded. Liability for incidental or consequential damages are excluded to the extent exclusion is permitted by law. Some states or countries do not allow limitations on how long an implied warranty lasts, and some states or countries do not allow the exclusion or limitation of incidental or consequential damages, so the above limitation and exclusion may not apply to you. This warranty gives you specific legal rights and you may also have other rights which vary from state to state and country to country.

STANDARD WARRANTY TERMS * ▲

Brand/Product Type	Consumer Use	Commercial Use
Vanguard™ ■	3 years	3 years
Extended Life Series™; I/C®; Intek™ I/C®; Intek™ Pro; Commercial Turf Series™ Professional Series™ with Dura-Bore™ Cast Iron Sleeve; 850 Series™ with Dura-Bore™ Cast Iron Sleeve; Snow Series MAX™ with Dura-Bore™ Cast Iron Sleeve All Other Briggs & Stratton Engines Featuring Dura-Bore™ Cast Iron Sleeve	2 years	1 year
All Other Briggs & Stratton Engines	2 years	90 days

* These are our standard warranty terms, but occasionally there may be additional warranty coverage that was not determined at time of publication. For a listing of current warranty terms for your engine, go to BRIGGSandSTRATTON.COM or contact your Authorized Briggs & Stratton Service Dealer.

▲ Home Standby Generator applications: 2 years consumer warranty only. No commercial warranty. This warranty does not apply to engines on equipment used for prime power in place of a utility. **Engines used in competitive racing or on commercial or rental tracks are not warranted.**

■ Vanguard installed on standby generators: 2 years consumer use, no warranty commercial use. Vanguard installed on utility vehicles: 2 years consumer use, 2 years commercial use. Vanguard 3-cylinder liquid cooled: see Briggs & Stratton 3/LC Engine Owner Warranty Policy.

The warranty period begins on the date of purchase by the first retail consumer or commercial end user, and continues for the period of time stated in the table above. "Consumer use" means personal residential household use by a retail consumer. "Commercial use" means all other uses, including use for commercial, income producing or rental purposes. Once an engine has experienced commercial use, it shall thereafter be considered as a commercial use engine for purposes of this warranty.

No warranty registration is necessary to obtain warranty on Briggs & Stratton Products. Save your proof of purchase receipt. If you do not provide proof of the initial purchase date at the time warranty service is requested, the manufacturing date of the product will be used to determine the warranty period.

About Your Warranty

Briggs & Stratton welcomes warranty repair and apologizes to you for being inconvenienced. Any Authorized Service Dealer may perform warranty repairs. Most warranty repairs are handled routinely, but sometimes requests for warranty service may not be appropriate.

If a customer differs with the decision of the Service Dealer, an investigation will be made to determine whether the warranty applies. Ask the Service Dealer to submit all supporting facts to his Distributor or the Factory for review. If the Distributor or the Factory decides that the claim is justified, the customer will be fully reimbursed for those items that are defective. To avoid misunderstanding which might occur between the customer and the Dealer, listed below are some of the causes of engine failure that the warranty does not cover.

Normal wear: Engines, like all mechanical devices, need periodic parts service and replacement to perform well. Warranty will not cover repair when normal use has exhausted the life of a part or an engine. Warranty would not apply if engine damage occurred because of misuse, lack of routine maintenance, shipping, handling, warehousing or improper installation. Similarly, warranty is void if the serial number of the engine has been removed or the engine has been altered or modified.

Improper maintenance: The life of an engine depends upon the conditions under which it operates, and the care it receives. Some applications, such as tillers, pumps and rotary mowers, are very often used in dusty or dirty conditions, which can cause what appears to be premature wear. Such wear, when caused by dirt, dust, spark plug cleaning grit, or other abrasive material that has entered the engine because of improper maintenance, is not covered by warranty.

This warranty covers engine related defective material and/or workmanship only, and not replacement or refund of the equipment to which the engine may be mounted. Nor does the warranty extend to repairs required because of:

- 1 Problems caused by parts that are not original Briggs & Stratton parts.
- 2 Equipment controls or installations that prevent starting, cause unsatisfactory engine performance, or shorten engine life. (Contact equipment manufacturer.)

- 3 Leaking carburetors, clogged fuel pipes, sticking valves, or other damage, caused by using contaminated or stale fuel.
- 4 Parts which are scored or broken because an engine was operated with insufficient or contaminated lubricating oil, or an incorrect grade of lubricating oil (check and refill when necessary, and change at recommended intervals). OIL GARD may not shut down running engine. Engine damage may occur if oil level is not properly maintained.
- 5 Repair or adjustment of associated parts or assemblies such as clutches, transmissions, remote controls, etc., which are not manufactured by Briggs & Stratton.
- 6 Damage or wear to parts caused by dirt, which entered the engine because of improper air cleaner maintenance, re-assembly, or use of a non-original air cleaner element or cartridge. At recommended intervals, clean and/or replace the filter as stated in the Operator's Manual.
- 7 Parts damaged by over-speeding, or overheating caused by grass, debris, or dirt, which plugs or clogs the cooling fins, or flywheel area, or damage caused by operating the engine in a confined area without sufficient ventilation. Clean engine debris at recommended intervals as stated in the Operator's Manual.
- 8 Engine or equipment parts broken by excessive vibration caused by a loose engine mounting, loose cutter blades, unbalanced blades or loose or unbalanced impellers, improper attachment of equipment to engine crankshaft, over-speeding or other abuse in operation.
- 9 A bent or broken crankshaft, caused by striking a solid object with the cutter blade of a rotary lawn mower, or excessive v-belt tightness.
- 10 Routine tune-up or adjustment of the engine.
- 11 Engine or engine component failure, i.e., combustion chamber, valves, valve seats, valve guides, or burned starter motor windings, caused by the use of alternate fuels such as, liquified petroleum, natural gas, altered gasolines, etc.

Warranty service is available only through authorized service dealers by Briggs & Stratton Corporation. Locate your nearest Authorized Service Dealer in our dealer locator map on BRIGGSandSTRATTON.COM or by calling 1-800-233-3723, or as listed in the 'Yellow Pages'.